



Intelligent Power Module TR-RPS1

Manual

Document LS10259-002TR-E
11/28/2022

Rev: **B**

P/N LS10259-002TR-E:B • ECN 00003637

Fire Alarm & Emergency Communication System Limitations

While a life safety system may lower insurance rates, it is not a substitute for life and property insurance!

An automatic fire alarm system—typically made up of smoke detectors, heat detectors, manual pull stations, audible warning devices, and a fire alarm control panel (FACP) with remote notification capability—can provide early warning of a developing fire. Such a system, however, does not assure protection against property damage or loss of life resulting from a fire.

An emergency communication system—typically made up of an automatic fire alarm system (as described above) and a life safety communication system that may include an autonomous control unit (ACU), local operating console (LOC), voice communication, and other various interoperable communication methods—can broadcast a mass notification message. Such a system, however, does not assure protection against property damage or loss of life resulting from a fire or life safety event.

The Manufacturer recommends that smoke and/or heat detectors be located throughout a protected premises following the recommendations of the current edition of the National Fire Protection Association Standard 72 (NFPA 72), manufacturer's recommendations, State and local codes, and the recommendations contained in the Guide for Proper Use of System Smoke Detectors, which is made available at no charge to all installing dealers. This document can be found at <http://www.systemsensor.com/appguides/>. A study by the Federal Emergency Management Agency (an agency of the United States government) indicated that smoke detectors may not go off in as many as 35% of all fires. While fire alarm systems are designed to provide early warning against fire, they do not guarantee warning or protection against fire. A fire alarm system may not provide timely or adequate warning, or simply may not function, for a variety of reasons:

Smoke detectors may not sense fire where smoke cannot reach the detectors such as in chimneys, in or behind walls, on roofs, or on the other side of closed doors. Smoke detectors also may not sense a fire on another level or floor of a building. A second-floor detector, for example, may not sense a first-floor or basement fire.

Particles of combustion or "smoke" from a developing fire may not reach the sensing chambers of smoke detectors because:

- Barriers such as closed or partially closed doors, walls, chimneys, even wet or humid areas may inhibit particle or smoke flow.
- Smoke particles may become "cold," stratify, and not reach the ceiling or upper walls where detectors are located.
- Smoke particles may be blown away from detectors by air outlets, such as air conditioning vents.
- Smoke particles may be drawn into air returns before reaching the detector.

The amount of "smoke" present may be insufficient to alarm smoke detectors. Smoke detectors are designed to alarm at various levels of smoke density. If such density levels are not created by a developing fire at the location of detectors, the detectors will not go into alarm.

Smoke detectors, even when working properly, have sensing limitations. Detectors that have photoelectric sensing chambers tend to detect smoldering fires better than flaming fires, which have little visible smoke. Detectors that have ionizing-type sensing chambers tend to detect fast-flaming fires better than smoldering fires. Because fires develop in different ways and are often unpredictable in their growth, neither type of detector is necessarily best and a given type of detector may not provide adequate warning of a fire.

Smoke detectors cannot be expected to provide adequate warning of fires caused by arson, children playing with matches (especially in bedrooms), smoking in bed, and violent explosions (caused by escaping gas, improper storage of flammable materials, etc.).

Heat detectors do not sense particles of combustion and alarm only when heat on their sensors increases at a predetermined rate or reaches a predetermined level. Rate-of-rise heat detectors may be subject to reduced sensitivity over time. For this reason, the rate-of-rise feature of each detector should be tested at least once per year by a qualified fire protection specialist. Heat detectors are designed to protect property, not life.

IMPORTANT! Smoke detectors must be installed in the same room as the control panel and in rooms used by the system for the connection of alarm transmission wiring, communications, signaling, and/or power. If detectors are not so located, a developing fire may damage the alarm system, compromising its ability to report a fire.

Audible warning devices such as bells, horns, strobes, speakers and displays may not alert people if these devices are located on the other side of closed or partly open doors or are located on another floor of a building. Any warning device may fail to alert people with a disability or those who have recently consumed drugs, alcohol, or medication. Please note that:

- An emergency communication system may take priority over a fire alarm system in the event of a life safety emergency.
- Voice messaging systems must be designed to meet intelligibility requirements as defined by NFPA, local codes, and Authorities Having Jurisdiction (AHJ).
- Language and instructional requirements must be clearly disseminated on any local displays.
- Strobes can, under certain circumstances, cause seizures in people with conditions such as epilepsy.
- Studies have shown that certain people, even when they hear a fire alarm signal, do not respond to or comprehend the meaning of the signal. Audible devices, such as horns and bells, can have different tonal patterns and frequencies. It is the property owner's responsibility to conduct fire drills and other training exercises to make people aware of fire alarm signals and instruct them on the proper reaction to alarm signals.
- In rare instances, the sounding of a warning device can cause temporary or permanent hearing loss.

A life safety system will not operate without any electrical power. If AC power fails, the system will operate from standby batteries only for a specified time and only if the batteries have been properly maintained and replaced regularly.

Equipment used in the system may not be technically compatible with the control panel. It is essential to use only equipment listed for service with your control panel.

Alarm Signaling Communications:

- **IP connections** rely on available bandwidth, which could be limited if the network is shared by multiple users or if ISP policies impose restrictions on the amount of data transmitted. Service packages must be carefully chosen to ensure that alarm signals will always have available bandwidth. Outages by the ISP for maintenance and upgrades may also inhibit alarm signals. For added protection, a backup cellular connection is recommended.
- **Cellular connections** rely on a strong signal. Signal strength can be adversely affected by the network coverage of the cellular carrier, objects and structural barriers at the installation location. Utilize a cellular carrier that has reliable network coverage where the alarm system is installed. For added protection, utilize an external antenna to boost the signal.
- **Telephone lines** needed to transmit alarm signals from a premise to a central monitoring station may be out of service or temporarily disabled. For added protection against telephone line failure, backup alarm signaling connections are recommended.

The most common cause of life safety system malfunction is inadequate maintenance. To keep the entire life safety system in excellent working order, ongoing maintenance is required per the manufacturer's recommendations, and UL and NFPA standards. At a minimum, the requirements of NFPA 72 shall be followed. Environments with large amounts of dust, dirt, or high air velocity require more frequent maintenance. A maintenance agreement should be arranged through the local manufacturer's representative. Maintenance should be scheduled as required by National and/or local fire codes and should be performed by authorized professional life safety system installers only. Adequate written records of all inspections should be kept.

Limit-F-2020

Installation Precautions

Adherence to the following will aid in problem-free installation with long-term reliability:

WARNING - Several different sources of power can be connected to the fire alarm control panel. Disconnect all sources of power before servicing. Control unit and associated equipment may be damaged by removing and/or inserting cards, modules, or inter-connecting cables while the unit is energized. Do not attempt to install, service, or operate this unit until manuals are read and understood.

CAUTION - System Re-acceptance Test after Software Changes:

To ensure proper system operation, this product must be tested in accordance with NFPA 72 after any programming operation or change in site-specific software. Re-acceptance testing is required after any change, addition or deletion of system components, or after any modification, repair or adjustment to system hardware or wiring. All components, circuits, system operations, or software functions known to be affected by a change must be 100% tested. In addition, to ensure that other operations are not inadvertently affected, at least 10% of initiating devices that are not directly affected by the change, up to a maximum of 50 devices, must also be tested and proper system operation verified.

This system meets NFPA requirements for operation at 0-49° C/32-120° F and at a relative humidity 93% ± 2% RH (non-condensing) at 32°C ± 2°C (90°F ± 3°F). However, the useful life of the system's standby batteries and the electronic components may be adversely affected by extreme temperature ranges and humidity. Therefore, it is recommended that this system and its peripherals be installed in an environment with a normal room temperature of 15-27° C/60-80° F.

Verify that wire sizes are adequate for all initiating and indicating device loops. Most devices cannot tolerate more than a 10% I.R. drop from the specified device voltage.

Like all solid state electronic devices, this system may operate erratically or can be damaged when subjected to lightning induced transients. Although no system is completely immune from lightning transients and interference, proper grounding will reduce susceptibility. Overhead or outside aerial wiring is not recommended, due to an increased susceptibility to nearby lightning strikes. Consult with the Technical Services Department if any problems are anticipated or encountered.

Disconnect AC power and batteries prior to removing or inserting circuit boards. Failure to do so can damage circuits.

Remove all electronic assemblies prior to any drilling, filing, reaming, or punching of the enclosure. When possible, make all cable entries from the sides or rear. Before making modifications, verify that they will not interfere with battery, transformer, or printed circuit board location.

Do not tighten screw terminals more than 9 in-lbs. Over-tightening may damage threads, resulting in reduced terminal contact pressure and difficulty with screw terminal removal.

This system contains static-sensitive components. Always ground yourself with a proper wrist strap before handling any circuits so that static charges are removed from the body. Use static suppressive packaging to protect electronic assemblies removed from the unit.

Units with a touchscreen display should be cleaned with a dry, clean, lint free/microfiber cloth. If additional cleaning is required, apply a small amount of Isopropyl alcohol to the cloth and wipe clean. Do not use detergents, solvents, or water for cleaning. Do not spray liquid directly onto the display.

Follow the instructions in the installation, operating, and programming manuals. These instructions must be followed to avoid damage to the control panel and associated equipment. FACP operation and reliability depend upon proper installation.

Precau-D2-11-2017

FCC Warning

WARNING: This equipment generates, uses, and can radiate radio frequency energy and if not installed and used in accordance with the instruction manual may cause interference to radio communications. It has been tested and found to comply with the limits for class A computing devices pursuant to Subpart B of Part 15 of FCC Rules, which is designed to provide reasonable protection against such interference when devices are operated in a commercial environment. Operation of this equipment in a residential area is likely to cause interference, in which case the user will be required to correct the interference at his or her own expense.

Canadian Requirements

This digital apparatus does not exceed the Class A limits for radiation noise emissions from digital apparatus set out in the Radio Interference Regulations of the Canadian Department of Communications.

Le présent appareil numérique n'émet pas de bruits radioélectriques dépassant les limites applicables aux appareils numériques de la classe A prescrites dans le Règlement sur le brouillage radioélectrique édicté par le ministère des Communications du Canada.

HARSH™, NIS™, and NOTI•FIRE•NET™ are all trademarks; and Acclimate® Plus™, FlashScan®, FAAST Fire Alarm Aspiration Sensing Technology®, Honeywell®, INSPIRE®, Intelligent FAAST®, NOTIFIER®, ONYX®, ONYXWorks®, SWIFT®, VeriFire®, and VIEW® are all registered trademarks of Honeywell International Inc. Triga™ is a trademark of TRIGA Life Safety Systems, LLC. Flexput®, Honeywell®, JumpStart®, and SWIFT® are registered trademarks of Honeywell International Inc. Fiplex® is a registered trademark of Fiplex Communications, Inc. Microsoft® and Windows® are registered trademarks of the Microsoft Corporation. Chrome™ and Google™ are trademarks of Google Inc. Firefox® is a registered trademark of The Mozilla Foundation.

©2022 by Honeywell International Inc. All rights reserved. Unauthorized use of this document is strictly prohibited.

Software Downloads

In order to supply the latest features and functionality in fire alarm and life safety technology to our customers, we make frequent upgrades to the embedded software in our products. To ensure that you are installing and programming the latest features, we strongly recommend that you download the most current version of software for each product prior to commissioning any system. Contact Technical Support with any questions about software and the appropriate version for a specific application.

Documentation Feedback

Your feedback helps us keep our documentation up-to-date and accurate. If you have any comments or suggestions about our online Help or printed manuals, you can email us.

Please include the following information:

- Product name and version number (if applicable)
- Printed manual or online Help
- Topic Title (for online Help)
- Page number (for printed manual)
- Brief description of content you think should be improved or corrected
- Your suggestion for how to correct/improve documentation

Send email messages to:

FireSystems.TechPubs@honeywell.com

Please note this email address is for documentation feedback only. If you have any technical issues, please contact Technical Services.

info@trigaglobal.com

or call +1 330-577-5199



This symbol (shown left) on the product(s) and / or accompanying documents means that used electrical and electronic products should not be mixed with general household waste. For proper treatment, recovery and recycling, contact your local authorities or dealer and ask for the correct method of disposal.

Electrical and electronic equipment contains materials, parts and substances, which can be dangerous to the environment and harmful to human health if the waste of electrical and electronic equipment (WEEE) is not disposed of correctly.

Table of Contents

| | |
|---|-----------|
| Section 1: Overview | 6 |
| 1.1: TRTR-RPS1-PS1 Description..... | 6 |
| 1.1.1: Maximum Number of SBUS Modules | 6 |
| 1.2: Agency Requirements | 8 |
| 1.2.1: UL 864 9th and 10th Edition | 9 |
| Section 2: Before You Begin Installing | 10 |
| 2.1: Inventory..... | 10 |
| 2.2: Environmental Specifications | 10 |
| 2.3: TR-RPS1 Board and Terminal Strip Description..... | 10 |
| 2.4: Earth Fault Resistance | 12 |
| 2.5: Calculating Current Draw and Standby Battery | 12 |
| 2.5.1: Worksheet Requirements..... | 12 |
| Filling in the Current Draw Worksheet, Table 2.4 | 12 |
| Maximum Battery Standby Load..... | 13 |
| 2.5.2: Current Draw Worksheet for SLC Devices | 13 |
| 2.6: Wiring Specifications..... | 16 |
| 2.6.1: Length Limitations..... | 16 |
| 2.6.2: Calculating Wiring Distance for SBUS Modules | 16 |
| Wiring Distance Calculation Example | 18 |
| Section 3: Installation | 19 |
| 3.1: Cabinet Mounting | 19 |
| 3.2: ORPS1000HV Replacement Board Installation..... | 19 |
| 3.3: Wire Routing..... | 20 |
| 3.4: AC Power..... | 20 |
| 3.5: Battery Connection | 21 |
| 3.6: Connecting the TR-RPS1 to the FACP..... | 21 |
| 3.6.1: Setting the Device ID..... | 22 |
| 3.7: Connecting SBUS Modules to the TR-RPS1 | 23 |
| 3.8: Flexput I/O Circuits | 23 |
| 3.8.1: Releasing Operations | 24 |
| 3.8.2: Conventional Notification Appliances | 24 |
| Class B Notification Wiring | 24 |
| Class A Notification Wiring | 24 |
| 3.8.3: Conventional Initiation Circuits | 25 |
| Class B Inputs | 25 |
| Class A Inputs..... | 25 |
| 3.8.4: Installing 2-Wire Smoke Detectors | 26 |
| Class B Installation | 26 |
| Class A Smoke Detector Installation | 26 |
| 3.8.5: Installing 4-Wire Smoke Detectors | 27 |
| Installing Class B 4-Wire Smoke Detectors | 27 |
| Installing Class A 4-Wire Smoke Detectors | 27 |
| 3.8.6: Auxiliary Power Configuration | 28 |
| Door Holder Power..... | 28 |
| Constant Power..... | 28 |
| Resettable Power..... | 28 |
| Sounder Sync Power..... | 28 |
| 3.9: Conventional Relay Installation | 28 |

Section 1: Overview

1.1 TRTR-RPS1-PS1 Description

The TR-RPS1 Intelligent Power Module provides additional power and circuits to the TR-2100ECS, TR-2100, and TR-75 FACPs. The TR-RPS1 can power all compatible modules, including SLC devices (via a TR-6815 SLC Expander), remote annunciators, notification appliances, auxiliary power modules, and all other compatible modules.



NOTE: The TR-75 does not use TR-6815 SLC expanders.

The TR-RPS1 has six Flexput circuits and two programmable relays. Outputs are rated 3.0 A (6.0 A total for each TR-RPS1). Relays are Form C rated at 2.5 A @ 24 VDC. Outputs and relays are fully programmable.

The TR-RPS1 is optically isolated, providing ground loop isolation and transient protection. It functions as an SBUS repeater which conditions the RS-485 signal and allows the module to drive up to 6,000 feet of additional SBUS wiring.

The TR-RPS1 is housed in a metal cabinet large enough to house two 17 AH batteries. The TR-RPS1 cabinet provides mounting studs for two Model TR-6815 SLC Expander modules.

The TR-RPS1 communicates to the main FACP via the SBUS. Each TR-RPS1 provides an additional 6,000 feet of SBUS wiring length to the main panel. As the drawings on the next pages illustrate, this allows for the distribution of modules, SLC devices, and outputs throughout an extremely large facility.

As well as expanding the wiring length capabilities of the FACP, the TR-RPS1 also expands the power capabilities by an additional 6.0 A of current.

1.1.1 Maximum Number of SBUS Modules

The chart below shows the maximum number of compatible modules that can be used in an Intelligent installation. Modules can be distributed among the main panel SBUS and each additional TR-RPS1 SBUS in virtually any combination.

| Module or Device | Maximum Number |
|---------------------------------------|---------------------------------|
| TR-RPS1 Intelligent Power Module | 8 per TR-75 installation |
| | 63 per TR-2100/ECS installation |
| TR-RD1G or TR-RD1R Remote | 8 per TR-75 installation |
| | 31 per TR-2100/ECS installation |
| TR-RD2G or TR-RD2R Remote Annunciator | 63 per TR-2100/ECS installation |
| TR-6815 SLC Expander | 63 per TR-2100/ECS installation |
| TR-5824 Serial/Parallel Modules | 4 per TR-2100/ECS installation |
| Outputs | 6 per TR-RPS1 |
| Conventional Relays | 2 per TR-RPS1 |

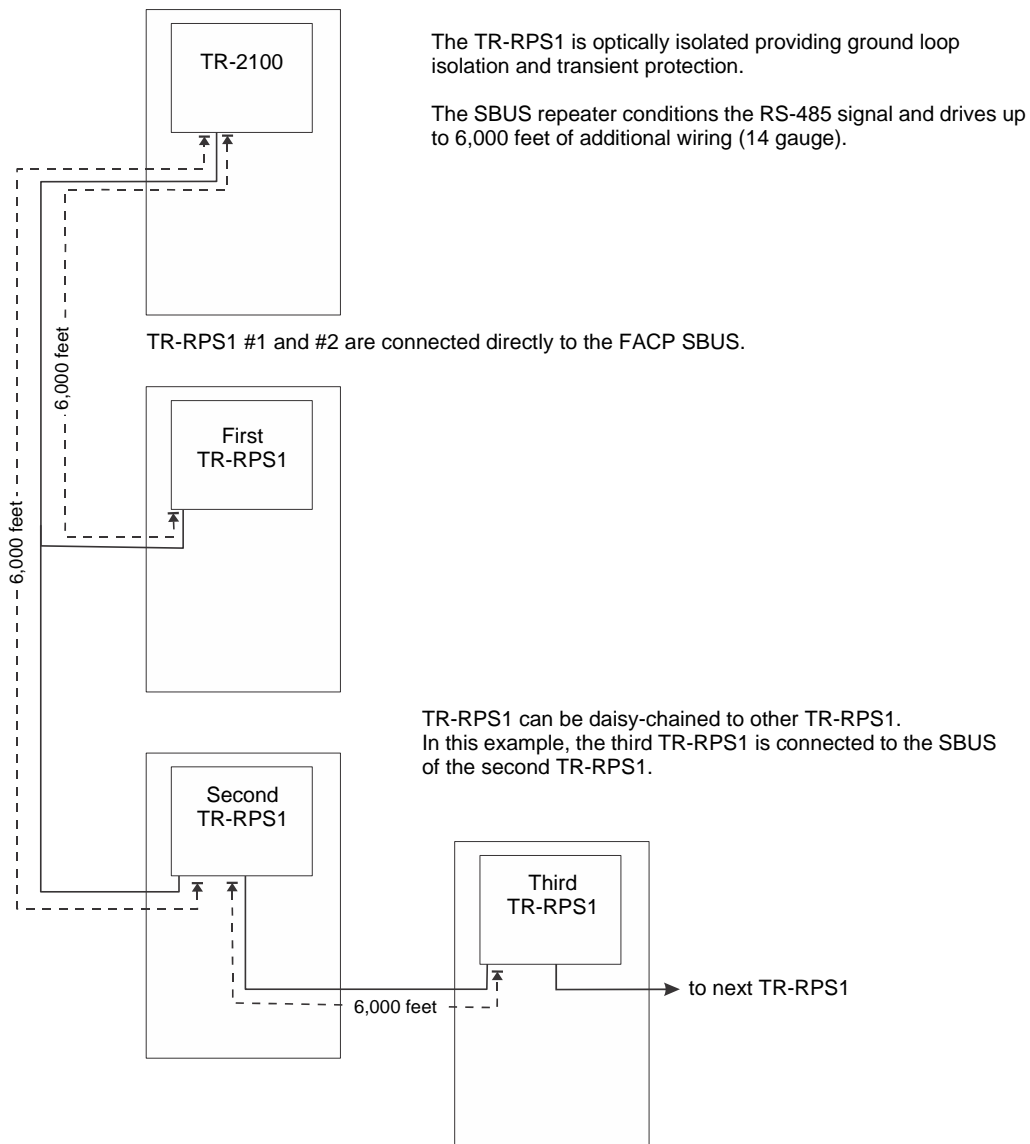

Figure 1.1 TR-RPS1 Installation Overview

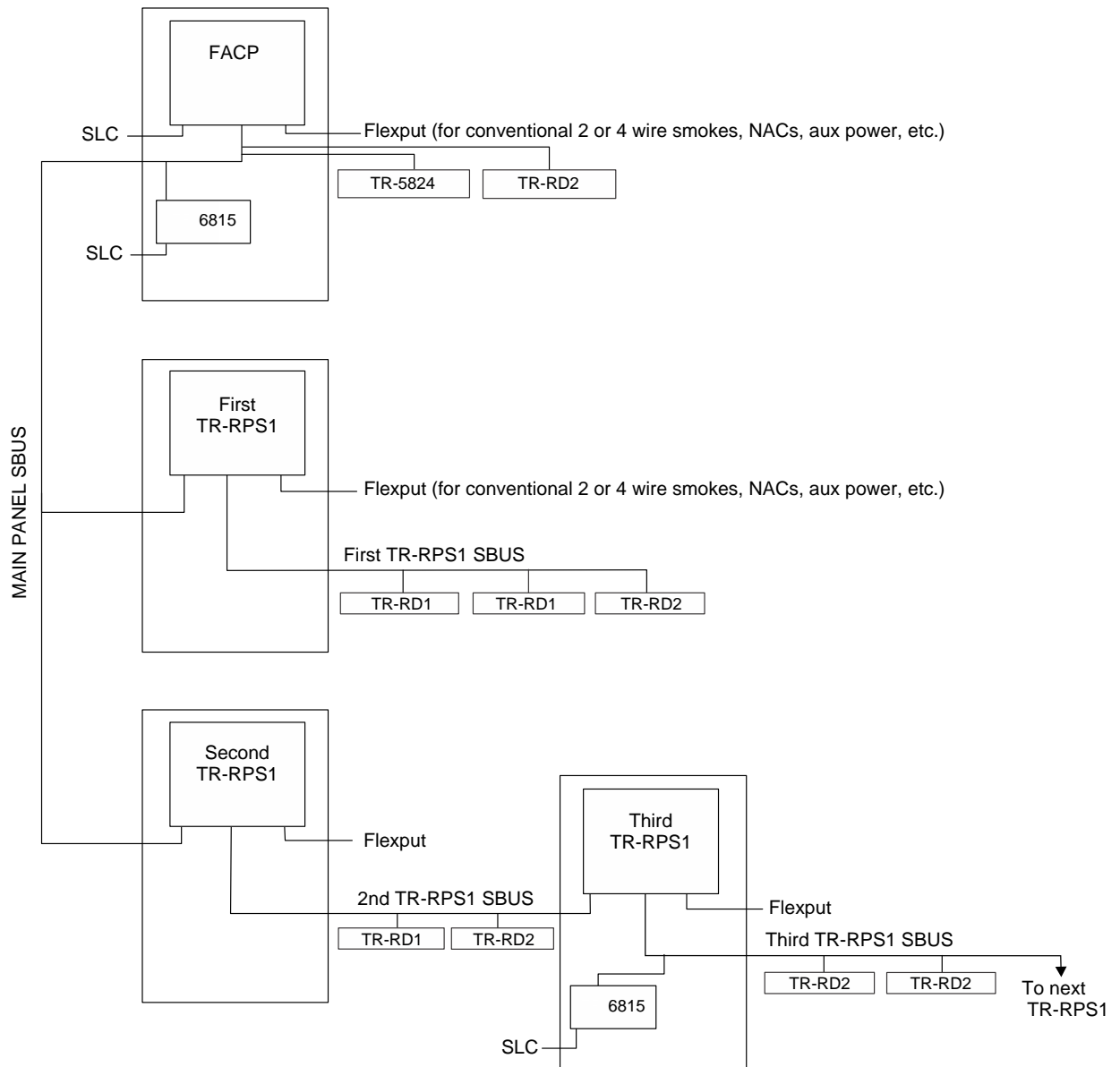

Figure 1.2 TR-RPS1 Installation Overview (Details Added)

1.2 Agency Requirements

The TR-RPS1 has the same requirements as the main control panel. These requirements are listed in the control panel manuals.

| FACP | Document Number |
|-------------------------------------|-----------------|
| TR-2100/ECS | LS10143-003TR-E |
| TR-75 | LS10147-004TR-E |
| Triga Device Compatibility Document | LS10167-006TR-E |
| Triga SLC Wiring Manual | LS10179-000TR-E |

Table 1.1 Related Documents

1.2.1 UL 864 9th and 10th Edition

- Per the UL Continuing Certification Program, UL 864 9th edition fire alarm control equipment will retain certification after the rollout of UL 10th edition (12/2/2018).
- Installations of UL 864 10th Edition certified equipment are permitted to use UL864 9th Edition certified equipment when approved by the local Authority Having Jurisdiction (AHJ).

For product compliance, refer to the UL/ULC listing cards located on the UL online certification directory.
<https://iq.ulprospector.com>

Section 2: Before You Begin Installing

2.1 Inventory

The TR-RPS1 ships with the following hardware:

- A cabinet with all hardware assembled
- Two keys for the front door
- Ten 4.7K ohm end-of-line resistors



NOTE: For UL installations, 4.7kΩ end-of-line resistor (ordered separately) must be used.

- A battery cable for batteries wired in series

2.2 Environmental Specifications

It is important to protect the TR-RPS1 control panel from water. To prevent water damage, the following conditions should be observed when installing the units:

- Do not mount directly on exterior walls, especially masonry walls (condensation).
- Do not mount directly on exterior walls below grade (condensation).
- Protect from plumbing leaks.
- Protect from splash caused by sprinkler system inspection ports.
- Do not mount in areas with humidity-generating equipment (such as dryers, production machinery).

When selecting a location to mount the TR-RPS1, the unit should be mounted where it will NOT be exposed to temperatures outside the range of 0°C-49°C (32°F-120°F) or humidity outside the range of 10%-93% at 30°C (86°F) non-condensing.

2.3 TR-RPS1 Board and Terminal Strip Description

Figure 2.1 shows the TR-RPS1 circuit board including location of terminals, the DIP switch for setting module ID, and the LED.

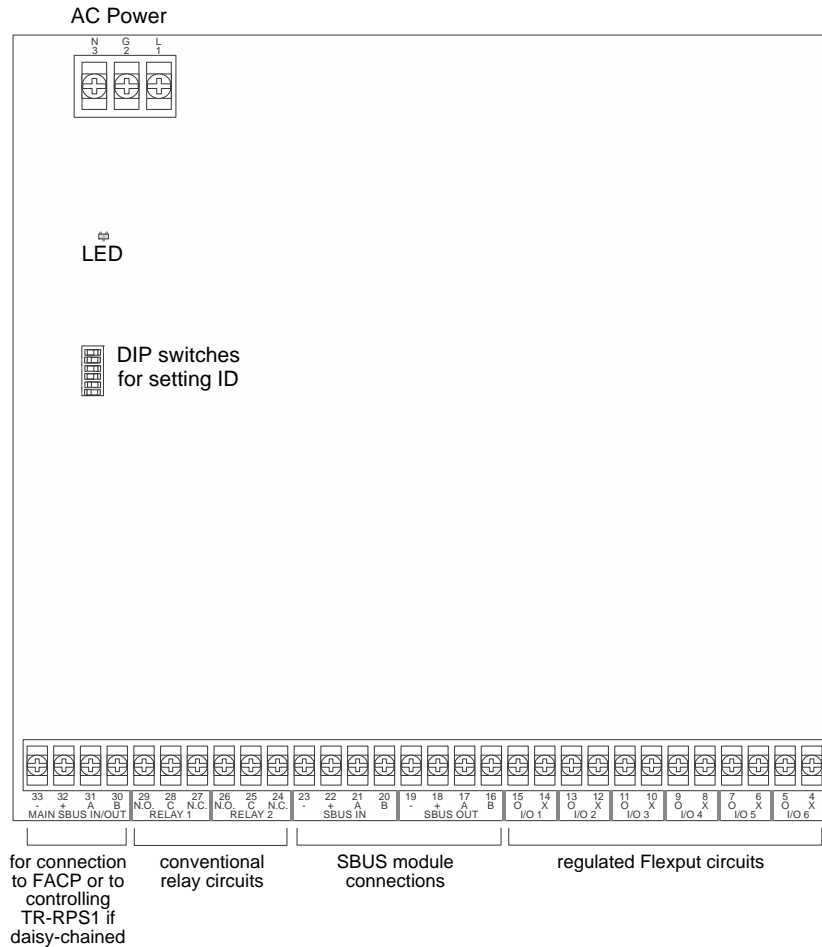

Figure 2.1 TR-RPS1 Board Layout

| Terminal # and Label | | Description | Rating | | |
|----------------------|------|--------------------|--|----------------------------|-----------------------------|
| | | | Voltage | Current | |
| 1 | L | AC input (hot) | 240 VAC, 50/60 Hz | 1.4 A | |
| 2 | G | Earth ground | N/A | N/A | |
| 3 | N | AC input (neutral) | 240 VAC, 50/60 Hz | 1.4 A | |
| 4 | X | I/O 6 ¹ | Flexput Circuit | 24 VDC | 3.0 A Notification Circuits |
| 5 | O | | | 100 mA Initiation Circuits | |
| 6 | X | I/O 5* | Flexput Circuit | 24 VDC | 3.0 A Notification Circuits |
| 7 | O | | | | 100 mA Initiation Circuits |
| 8 | X | I/O 4* | Flexput Circuit | 24 VDC | 3.0 A Notification Circuits |
| 9 | O | | | | 100 mA Initiation Circuits |
| 10 | X | I/O 3* | Flexput Circuit | 24 VDC | 3.0 A Notification Circuits |
| 11 | O | | | | 100 mA Initiation Circuits |
| 12 | X | I/O 2* | Flexput Circuit | 24 VDC | 3.0 A Notification Circuits |
| 13 | O | | | | 100 mA Initiation Circuits |
| 14 | X | I/O 1* | Flexput Circuit | 24 VDC | 3.0 A Notification Circuits |
| 15 | O | | | | 100 mA Initiation Circuits |
| 16 | B | SBUS OUT | SBUS communication | 5 VDC | 100 mA |
| 17 | A | | SBUS power | 24 VDC | 1.0 A |
| 18 | + | | | | |
| 19 | - | | | | |
| 20 | B | SBUS IN | Used for Class A installations | | |
| 21 | A | | | | |
| 22 | + | | | | |
| 23 | - | | | | |
| 24 | N.C. | RELAY 2 | General Purpose Relay 2 | 24 VDC | 2.5 A |
| 25 | C | | | | |
| 26 | N.O. | | | | |
| 27 | N.C. | RELAY 1 | General Purpose Relay 1 | 24 VDC | 2.5 A |
| 28 | C | | | | |
| 29 | N.O. | | | | |
| 30 | B | SBUS IN/ OUT | TR-RPS1 communication with main panel or to controlling TR-RPS1 if daisy-chained | 5 VDC | 100 mA |
| 31 | A | | | | |
| 32 | + | MAIN | TR-RPS1 SBUS power (from FACP) | 24 VDC | 10 mA |
| 33 | - | | | | |

Table 2.1 Terminal Strip Description and Electrical Ratings

1 Regulated/special application when used for releasing

2.4 Earth Fault Resistance

Table 2.2 lists the earth fault resistance detection, in ohms, for each applicable terminal on the FACP.

| Function | Terminal Number | Terminal Label | | Low Biased | | High Biased | |
|--------------------------------|-----------------|----------------|----------|------------|--------------|-------------|-------------|
| | | | | High Trip | High Restore | Low Trip | Low Restore |
| Flexput Notification Circuits | 4 | X | I/O 6 | - | - | 0 | 0 |
| | 5 | O | | 0 | 0 | - | - |
| | 6 | X | I/O 5 | - | - | 0 | 0 |
| | 7 | O | | 0 | 0 | - | - |
| | 8 | X | I/O 4 | - | - | 0 | 0 |
| | 9 | O | | 0 | 0 | - | - |
| | 10 | X | I/O 3 | - | - | 0 | 0 |
| | 11 | O | | 0 | 0 | - | - |
| | 12 | X | I/O 2 | - | - | 0 | 0 |
| | 13 | O | | 0 | 0 | - | - |
| | 14 | X | I/O 1 | - | - | 0 | 0 |
| | 15 | O | | 0 | 0 | - | - |
| SBUS Communication | 16 | B | SBUS OUT | - | - | 0 | 0 |
| | 17 | A | | - | - | 0 | 0 |
| SBUS Power | 18 | + | | 0 | 0 | - | - |
| | 19 | - | | - | - | 0 | 0 |
| Used for Class A Installations | 20 | B | SBUS IN | - | - | 0 | 0 |
| | 21 | A | | - | - | 0 | 0 |
| | 22 | + | | 0 | 0 | - | - |
| | 23 | - | | - | - | 0 | 0 |

Table 2.2 Earth Fault Resistance Values by Terminal

2.5 Calculating Current Draw and Standby Battery

This section contains instructions and tables for calculating current draws and standby battery needs.

2.5.1 Worksheet Requirements

The following steps must be taken when determining TR-RPS1 current draw and standby battery requirements.

Filling in the Current Draw Worksheet, Table 2.4

1. For the TR-RPS1, the worst case current draw is listed for the panel, addressable devices, and SLC expanders. Fill in the number of addressable devices and expanders that will be used in the system and compute the current draw requirements for alarm and standby.
2. Add up the current draw for all auxiliary devices and record in the table at Line B.
3. Add up all notification appliance loads and record in the table at Line C.
4. For notification appliances and auxiliary devices not mentioned in the manual, refer to the device manual for the current ratings.
5. Make sure that the total alarm current calculated, including current for the panel itself, does not exceed 6.0 A. This is the maximum alarm current allowable.
6. Complete the remaining instructions in the table for determining battery size requirements.

Maximum Battery Standby Load

Table 2.3 shows the maximum battery standby load for the TR-RPS1 based on 24 and 60 hours of standby. The numbers below have a built in 20% derating factor for the battery amp-hour capacity. The standby load calculations of line G in the Current Draw Calculation Worksheet must be less than the number shown in Table 2.3 for the battery size used and standby hours required.

| Rechargeable Battery Size | Max. Load for 24 hrs. Standby, 5 mins. Alarm | ¹ Max. Load for 60 hrs. Standby, 5 mins. Alarm |
|---------------------------|--|---|
| 7 AH | 270 mA | 105 mA |
| 12 AH | 475 mA | 190 mA |
| 17 AH | 685 mA | 270 mA |
| 33 AH | 1370 mA | 540 mA |

Table 2.3 Maximum Battery Standby Load

¹ Required for NFPA 72 Auxiliary Protected Fire Alarm systems for Fire Alarm Service (City Box) and Remote Station Protected Fire Alarm systems (Polarity Reversal) and Digital Alarm Communicator/Transmitter (DACT)



NOTE: The maximum battery size for FM (Factory Mutual) installations is 33AH.

2.5.2 Current Draw Worksheet for SLC Devices

For *each* TR-RPS1 in the installation, use this worksheet to determine current requirements during alarm and battery standby operation. See individual FACP manual for maximum number of devices.

| Device | # of Devices | Current per Device | | Standby Current | Alarm Current |
|--|--------------|--------------------------------------|-------------------------------|-----------------|----------------------|
| For each device use this formula: This column X This column = Current per number of devices. | | | | | |
| TR-RPS1 Intelligent Power Module (Current draw from battery) | 1 | Standby | 40 mA | 40 mA | |
| | | Alarm: | 160 mA | | 160 mA |
| Additional TR-RPS1 (Daisy-chained to this module) | (7 max.) | Standby | 10 mA | mA | |
| | | Alarm: | 10 mA | | mA |
| Addressable SLC Detectors | | | | | |
| TR-PHOTO-W/-IV | | | | mA | mA |
| TR-PHOTO-T-W/- | | | | mA | mA |
| TR-PHOTO-R-W/-IV | | Standby: Alarm: | 0.2 mA 4.5 mA ¹ | mA | mA |
| TR-HEAT-W/-IV | | | | mA | mA |
| TR-HEAT-HT-W/-IV | | | | mA | mA |
| TR-HEAT-ROR-W/-IV | | | | mA | mA |
| TR-OSI-RI | | | | SLC | Standby/Alarm: 20 mA |
| | | Aux. Pwr | Standby: 22 mA | mA | |
| | | | Alarm: 20 mA | | mA |
| TR-DNR/DNRW ² (non-relay) | | None, included with TR-PHOTO-R-W/-IV | | | |
| TR-DNR ³ (with relay) | | None, included with & TR-RELAY | | | |
| TR-FIRE-CO-W/-IV | | SLC | Standby: 0.20 mA | mA | |
| | | | Alarm: 4.5 mA | | mA |
| TR-PTIR-W/-IV | | SLC | Standby: 0.20 mA | mA | |
| | | | Alarm: 4.5 mA | | mA |
| Addressable SLC Modules | | | | | |
| TR-MONITOR | | Standby/Alarm 0.375 mA | | mA | mA |
| TR-MINIMON | | Standby/Alarm 0.375 mA | | mA | mA |
| TR-PULL-SA/TR-PULL-DA | | Standby/Alarm 0.3 mA | | mA | mA |
| TR-MONITOR-2 | | Standby/Alarm: 0.75 mA | | mA | mA |
| TR-MONITOR-10 | | Standby/Alarm: 3.5 mA | | mA | mA |

Table 2.4 Current Draw Worksheet for IDP SLC Devices

| Device | # of Devices | Current per Device | | Standby Current | Alarm Current | |
|---|--------------|--------------------------|-------------------|-----------------|---------------|----|
| TR-CONTROL | | SLC | Standby | 0.375 mA | mA | |
| | | | Alarm: | 0.375 mA | | mA |
| | | Aux Pwr | Standby | 1.7 mA | mA | |
| | | | Alarm: | 6.5mA | | mA |
| TR-CONTROL-6 | | SLC | Standby | 2.65 mA | mA | |
| | | | Alarm: | 35 mA | | mA |
| | | Aux Pwr | Standby | 8 mA | mA | |
| | | | Alarm: | 20 mA | | mA |
| TR-RELAY | | Standby/Alarm: | | 0.255 mA | mA | mA |
| TR-RELAY-6 | | Standby: | | 1.9 mA | mA | |
| | | Alarm: | | 32 mA | | mA |
| TR-RELAYMON-2 | | Standby: | | 1.3 mA | mA | |
| | | Alarm: | | 24 mA | | mA |
| TR-ZONE | | Aux Pwr | Standby | 12 mA | mA | |
| | | | Alarm: | 90 mA | | mA |
| | | SLC | Standby: | 0.27 mA | mA | |
| | | | Alarm: | 5.1 mA | | |
| TR-ZONE-6 | | Aux Pwr | Standby | 50 mA | mA | |
| | | | Alarm: | 70 mA | | mA |
| | | SLC | Standby | 2.3 mA | mA | |
| | | | Alarm: | 40 mA | | mA |
| SLC Accessories | | | | | | |
| TR-B200SR-W/-IV Sounder Base | | Aux Pwr | Standby: | 0.5 mA | mA | |
| | | | Alarm: | 35 mA | | mA |
| | | SLC | Standby | 0.3 mA | mA | |
| TR-B200S-W/-IV Intelligent Sounder Base | | Aux Pwr | Standby: | 0.5 mA | mA | |
| | | | Alarm: (high vol) | 35 mA | | mA |
| | | SLC | Standby | 0.3 mA | mA | |
| TR-B200SR-LF-W/-IV Low Frequency Sounder Base | | Aux Pwr | Standby: | 1 mA | mA | |
| | | | Alarm: | 125 mA | | mA |
| TR-B200S-LF-W/-IV Low Frequency Sounder Base | | Aux Pwr | Standby | 0.55 mA | mA | |
| | | | Alarm (high vol) | 140 mA | | mA |
| | | SLC | Standby | 0.30 mA | mA | |
| TR-B224RB-W/-IV Relay Base | | Standby/Alarm: | | 0.17 mA | mA | mA |
| RTS151 | | Alarm: | | 10 mA | | mA |
| RTS151KEY | | Alarm: | | 12 mA | | mA |
| TR-RA100Z | | Alarm: | | 10 mA | | mA |
| SLC Isolator Devices | | | | | | |
| TR-ISO (Isolator Module) | | Standby: | | 0.45 mA | mA | mA |
| | | Isolation: | | 17 mA | | |
| TR-ISO-6 (6 Fault Isolator Module) | | Standby: (per circuit) | | 0.45 mA | mA | |
| | | Isolation: (per circuit) | | 17 mA | | mA |
| TR-B224BI-W/-IV Isolator Base | | Standby: | | 0.45 mA | mA | |
| | | Isolation: | | 15 mA | | mA |
| Accessories Modules ⁴ | | | | | | |
| TR-6815 SLC Loop Expander | | Standby: | | 78 mA | mA | |
| | | Alarm: | | 78 mA | | mA |
| TR-RD2G/R Remote LCD Annunciator | | Standby: | | 27 mA | mA | |
| | | Alarm: | | 53 mA | | mA |

Table 2.4 Current Draw Worksheet for IDP SLC Devices

| Device | # of Devices | Current per Device | Standby Current | Alarm Current |
|---|--|------------------------------------|-----------------|---------------|
| TR-RD1G/R Remote LCD Annunciator | | Standby: 58 mA | mA | |
| | | Alarm: 68 mA | | mA |
| TR-5824 Serial/Parallel Module | | Standby/Alarm: 45 mA | mA | mA |
| TR-RPS1 Power Supply | | Standby/Alarm (SBUS): 10 mA | mA | mA |
| TR-5865-4 LED Annunciator (with reset and silence switches) | | Standby: 35 mA | mA | |
| | | Alarm: 145 mA | | mA |
| TR-5865-3 LED Annunciator Module | | Standby: 35 mA | mA | |
| | | Alarm: 145 mA | | mA |
| TR-5880 LED I/O Module | | Standby: 35 mA | mA | |
| | | Alarm: 200 mA | | mA |
| TR-5883 Relay Interface | | Standby: 0 mA | mA | |
| | | Alarm: (22 mA/relay) 220 mA | | mA |
| TR-50W Voice Amplifier with/without TR-CE4 | | Standby/Alarm (SBUS): 10 mA | mA | mA |
| TR-125W Voice Amplifier with/without TR-CE4 | | Standby/Alarm (SBUS): 10 mA | mA | mA |
| TR-INT50W Internal Amplifier | | Standby: 52 mA | mA | |
| | | Alarm @ 25V: 275 mA | | mA |
| | | Alarm @ 70V: 310 mA | | mA |
| TR-DUAL50W Dual Voice Amp | | Standby/Alarm (SBUS): 10 mA | mA | mA |
| TR-50WBU Back-Up Amplifier | | Standby/Alarm: 10 mA | mA | mA |
| ECS-NVCM Voice Control Module | | Standby/Alarm: 59 mA | mA | mA |
| ECS-RVM Remote Voice Module | | Standby: 60 mA | | |
| | | Alarm: 80 mA | | |
| TR-SW24 Switch Expander | | Standby: 10 mA | mA | |
| | | Alarm: 25 mA | | mA |
| TR-RPU Remote Paging Unit | | Standby: 70 mA | mA | |
| | | Alarm: 100 mA | | mA |
| TR-LOC2100 Local Operating Console | | Standby: 87 mA | mA | |
| | | Alarm: 133 mA | | mA |
| TR-LOC2100 Local Operating Console with one TR-SW24 Expander | | Standby: 97 mA | mA | |
| | | Alarm: 158 mA | | mA |
| TR-LOC2100 Local Operating Console with two TR-SW24 Expanders | | Standby: 107 mA | mA | |
| | | Alarm: 183 mA | | mA |
| Network Cards | | | | |
| TR-NIC Network Interface Card | | Standby/Alarm: 21 mA | mA | mA |
| TR-FML Fiber Optic Multi Mode | | Standby/Alarm: 53 mA | mA | mA |
| TR-FSL Fiber Optic Single Mode | | Standby/Alarm: 79 mA | mA | mA |
| Wireless Modules | | | | |
| TRW-GI Wireless Gateway | | Max current using ext supply 40 mA | mA | mA |
| | | Max current SLC Power 24 mA | mA | mA |
| A Total System Current | | | | |
| Auxiliary Devices | Refer to devices manual for current rating | | | |
| | | Alarm/Standby: mA | mA | mA |
| | | Alarm/Standby: mA | mA | mA |
| B Auxiliary Devices Current ⁵ | | | | |
| Notification Devices | Refer to device manual for current rating | | | |
| | | Alarm: mA | | mA |
| | | Alarm: mA | | mA |

Table 2.4 Current Draw Worksheet for IDP SLC Devices

| | Device | # of Devices | Current per Device | Standby Current | Alarm Current |
|---|---|--------------|--------------------|-----------------|---------------|
| | | | Alarm: mA | | mA |
| C | Notification Appliances Current | | | | mA |
| D | Total current ratings of all devices in system (line A + line B + C) | | | mA | mA |
| E | Total current ratings converted to amperes (line D x 0.001): | | | A | A |
| F | Number of standby hours | | | H | |
| G | Multiply lines E and F. Total standby AH | | | AH | |
| H | Alarm sounding period in hours. (For example, 5 minutes = 0.0833 hours) | | | | H |
| I | Multiply lines E and H. Total alarm AH | | | | AH |
| J | Add lines G and I. Total ampere hours required⁶ | | | AH | |

Table 2.4 Current Draw Worksheet for IDP SLC Devices

- 1 The FACP can only support 5 devices with LEDs on. The current draw has been added to the panels alarm current.
- 2 The TR-PHOTO-R-W is sold separately from the DNR. Current draw for the DNR + TR-PHOTO-R-W is calculated by increasing the "Number of Devices" column for each TR-PHOTO-R-W used with a DNR.
- 3 The TR-PHOTO-R-W is sold separately from the DNR. Current draw for the DNR + TR-PHOTO-R-W is calculated by increasing the "Number of Devices" column for each TR-PHOTO-R-W used with a DNR.
- 4 Maximum SBUS address capacity is determined by the amount of SBUS bandwidth consumed by each SBUS module. Refer to the FACP manual for SBUS limitations.
- 5 If there are door holders in the system, there is no need to consider door holder current for alarm/battery standby, because power is removed during that time. However, during normal operation, door holders draw current and must be included in the 1.8 A total current that can be drawn from the panel.
- 6 Use next size battery with capacity greater than required.

2.6 Wiring Specifications

2.6.1 Length Limitations

This section contains information on calculating SBUS wire distances and the types of wiring configurations (Class A and B).

2.6.2 Calculating Wiring Distance for SBUS Modules

The following instructions will guide you in determining the type of wire and the maximum wiring distance that can be used with SBUS accessory modules.

To calculate the wire gauge that must be used to connect SBUS modules to the panel, it is necessary to calculate the total worst case current draw for all modules on a single 4-conductor bus. The total worst case current draw is calculated by adding the individual worst case currents for each module. The individual worst case values are shown in the table below.



NOTE: Total worst case current draw on a single SBUS cannot exceed 1 amp. If a large number of accessory modules are required and the worst case current draw will exceed the 1 amp limit, then the current draw must be distributed using TR-RPS1 Power Expanders. Each TR-RPS1 Power Expander provides an additional SBUS, with an additional 1 amp of SBUS current. Wiring distance calculations are done separately for each TR-RPS1, and separately for the panel itself.

| Model Number | Worst Case Current Draw |
|--|-------------------------|
| TR-RD2G/R, TR-RD1G/R Fire Annunciators | 0.120 amps |
| TR-6815 SLC Loop Expander | 0.078 amps |
| TR-5824 Serial/Parallel Printer Interface Module | 0.040 amps |
| TR-5880 LED I/O Module | 0.250 amps |
| TR-5865 LED Annunciator | 0.200 amps |
| TR-RPS1 Intelligent Power Supply | 0.010 amps |
| TR-50W | 0.010 amps |
| TR-125W | 0.010 amps |
| TR-DUAL50W | 0.010 amps |
| TR-DUAL50W with TR-50WBU | 0.010 amps |
| ECS-NVCM Network Voice Control Module | 0.059 amps |
| ECS-EMG keypad | 0.06 amps |
| TR-NIC Network Interface Card | 0.021 amps |
| TR-F485C Fiber Converter | 0.125 amps |

After calculating the total worst case current draw, Table 2.5 specifies the maximum distance the modules can be located from the panel on a single wire run. The table insures 6.0 volts of line drop maximum. In general, the wire length is limited by resistance, but for heavier wire gauges, capacitance is the limiting factor.

These cases are marked in the chart with an asterisk (*). Maximum length can never be more than 6,000 feet, regardless of gauge used. (The formula used to generate this chart is shown in the chart below).

| Wiring Distance: SBUS Modules to Panel | | | | |
|---|-----------------|-----------------|-----------------|-----------------|
| Total Worst Case Current Draw (amps) | 22 Gauge | 18 Gauge | 16 Gauge | 14 Gauge |
| 0.100 | 1852 ft. | 4688 ft. | * 6000 ft. | * 6000 ft. |
| 0.200 | 926 ft. | 2344 ft. | 3731 ft. | 5906 ft. |
| 0.300 | 617 ft. | 1563 ft. | 2488 ft. | 3937 ft. |
| 0.400 | 463 ft. | 1172 ft. | 1866 ft. | 2953 ft. |
| 0.500 | 370 ft. | 938 ft. | 1493 ft. | 2362 ft. |
| 0.600 | 309 ft. | 781 ft. | 1244 ft. | 1969 ft. |
| 0.700 | 265 ft. | 670 ft. | 1066 ft. | 1687 ft. |
| 0.800 | 231 ft. | 586 ft. | 933 ft. | 1476 ft. |
| 0.900 | 206 ft. | 521 ft. | 829 ft. | 1312 ft. |
| 1.000 (Max) | 185 ft. | 469 ft. | 746 ft. | 1181 ft. |

Table 2.5 Wire Distances Per Wire Gauge

The following formulas were used to generate the wire distance chart

$$\text{Maximum Resistance (Ohms)} = \frac{6.0 \text{ Volts}}{\text{Total Worst Case Current Draw (amps)}}$$

$$\text{Maximum Wire Length (Feet)} = \frac{\text{Maximum Resistance (Ohms)}}{\text{Rpu}} * 500$$

(6000 feet maximum)

where: Rpu = Ohms per 1000 feet for various Wire Gauges (see table below)

| Wire Gauge | Ohms per 1000 feet (Rpu) |
|-------------------|---------------------------------|
| 22 | 16.2 |
| 18 | 6.4 |
| 16 | 4.02 |
| 14 | 2.54 |

Table 2.6 Typical Wire Resistance Per 1000 ft.

Wiring Distance Calculation Example

Suppose a system is configured with the following SBUS modules:

2 - TR-RD1G/R Fire Annunciators

1 - TR-RPS1 Intelligent Power Expander

1 - TR-5865 LED Fire Annunciator

1 - TR-5824 Parallel/Serial Interface

The total worst case current is calculated as follows:

| | | |
|-------------------------------|------------------|--------------|
| TR-RD1G/R Current Draw | = 2 x 0.100 amps | = 0.200 amps |
| TR-RPS1 Current Draw | = 1 x 0.010 amps | = 0.010 amps |
| TR-5865 Current Draw | = 1 x 0.200 amps | = 0.200 amps |
| TR-5824 Current Draw | = 1 x 0.040 amps | = 0.040 amps |
| Total Worst Case Current Draw | | = 0.450 amps |

Using this value, and referring to the Wiring Distance table, it can be found that the available options are:

- 370 feet maximum using 22 Gauge wire
- 938 feet maximum using 18 Gauge wire
- 1493 feet maximum using 16 Gauge wire
- 2362 feet maximum using 14 Gauge wire

Section 3: Installation

TR-RPS1 installation involves the following steps.

1. Mount cabinet to wall (Section 3.1).
2. Connect AC power (Section 3.4) and backup battery (Section 3.5).
3. Wire the FACP to the controlling TR-RPS1 (Section 3.6).
4. Set an ID for the TR-RPS1 (Section 3.6.1).
5. Install and wire SBUS modules that will be powered by this TR-RPS1 (Section 3.7).
6. Install and wire any outputs (conventional relays, notification appliances, auxiliary power modules, etc.) that will be powered by this TR-RPS1. See Section 3.8.2 for notification appliance wiring information. Refer to the FACP Installation Manual for software configuration information and other information about installing outputs.

3.1 Cabinet Mounting

1. Mark and pre-drill hole in the wall for the center top keyhole mounting bolt using the dimensions illustrated below.
2. Install center top fastener in the wall with the screw head protruding.
3. Place backbox over the top screw, level and secure.
4. Mark and drill the left and right lower mounting holes.
5. Install remaining fasteners and tighten.

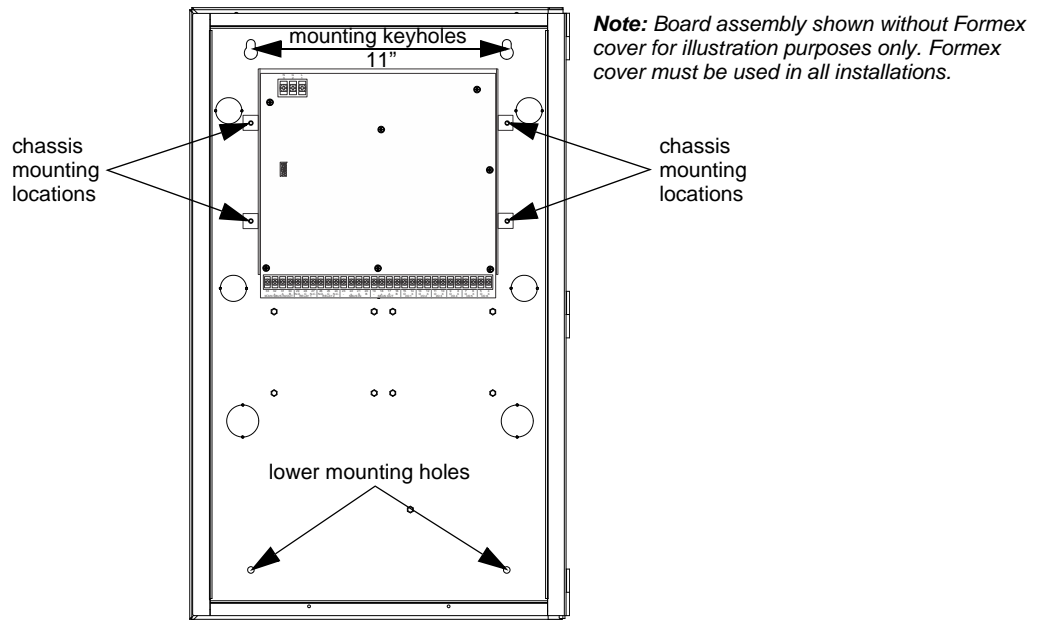

Figure 3.1 TR-RPS1 Cabinet Mounting

3.2 ORPS1000HV Replacement Board Installation



CAUTION: REMOVE POWER

MAKE CERTAIN ALL POWER (AC AND DC) IS REMOVED BEFORE ANY REPLACEMENT WORK IS PERFORMED.

1. Disconnect all wiring from the board.
2. Remove the four nuts which secure the chassis to the cabinet. Refer to Figure 3.1 for mounting locations.
3. Replace the board assembly and secure with nuts removed in step 2.
4. Reconnect wiring.

3.3 Wire Routing

Follow power-limited wiring techniques. Maintain 0.25" spacing between power-limited and non-power-limited circuits and separate high and low voltage circuits.

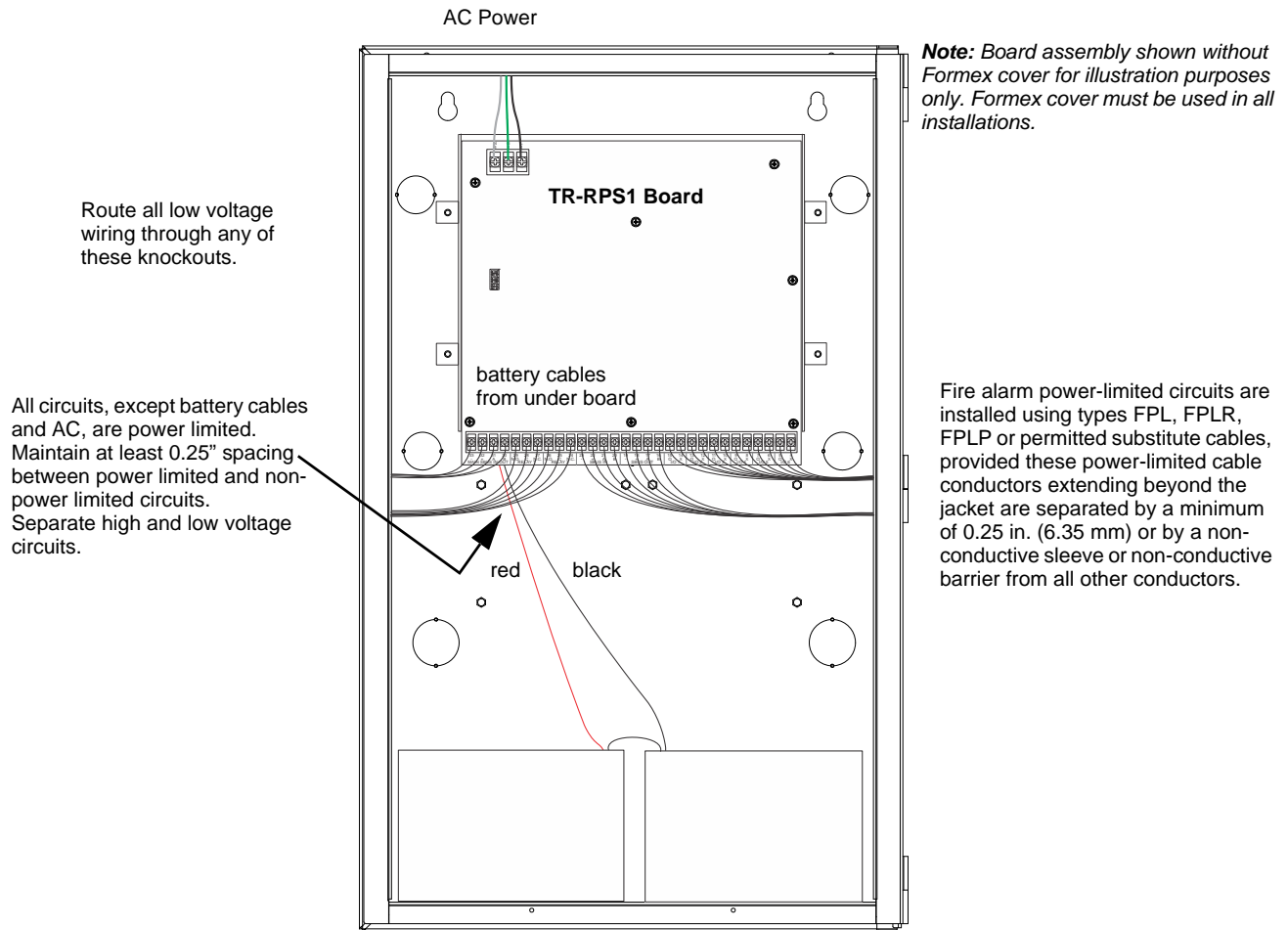

Figure 3.2 Wire Routing Example

3.4 AC Power

At installation, connect the AC terminals to a 240 VAC source as shown in Figure 3.3. It may be necessary for a professional electrician to make this connection.

The AC terminals are rated 240 VAC, 50 or 60 Hz, 1.4A.

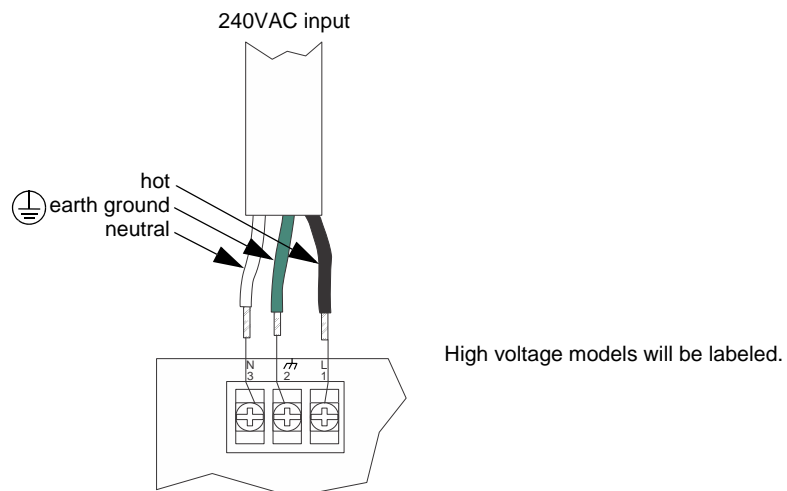

Figure 3.3 AC Power Connection

3.5 Battery Connection

The TR-RPS1 battery charge capacity is 7 to 33 AH. Use 12V batteries of the same AH rating. Determine the correct AH rating as per the current load calculation (see Table 2.4).



NOTE: If the backup battery requirements indicate the use of batteries that are too large to fit into the TR-RPS1 cabinet, use the RBB Remote Battery Box cabinet. Refer to the *RBB Installation Instructions #151306*.

Wire batteries in series to produce a 24-volt equivalent. Do not parallel batteries to increase the AH rating.

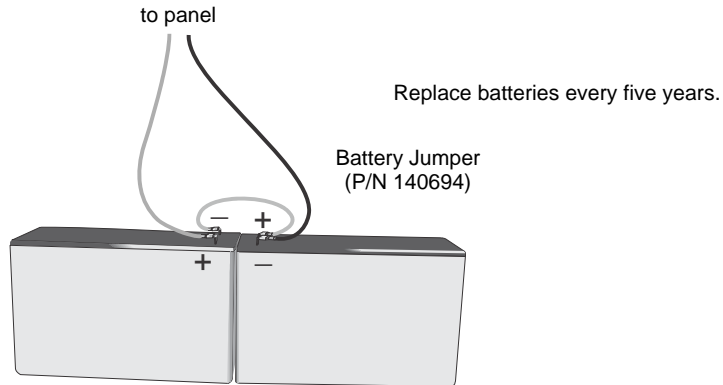

Figure 3.4 Battery Connection

3.6 Connecting the TR-RPS1 to the FACP

1. Connect the TR-RPS1 to the appropriate SBUS. The TR-RPS1 can be connected directly to the FACP or it can be daisy-chained to another TR-RPS1. Refer to Figures 3.5 and 3.6.
2. Use the onboard DIP switch to assign an ID number. (See Section 3.6.1) Figure 2.1 shows the location of the DIP switches on the TR-RPS1 board.
3. Add the TR-RPS1 module to the system and configure the module using JumpStart auto-programming or by manually entering information into the FACP.

It is possible to assign a name to the module. These procedures are described in the FACP Installation Manuals. Refer to Table 1.1.

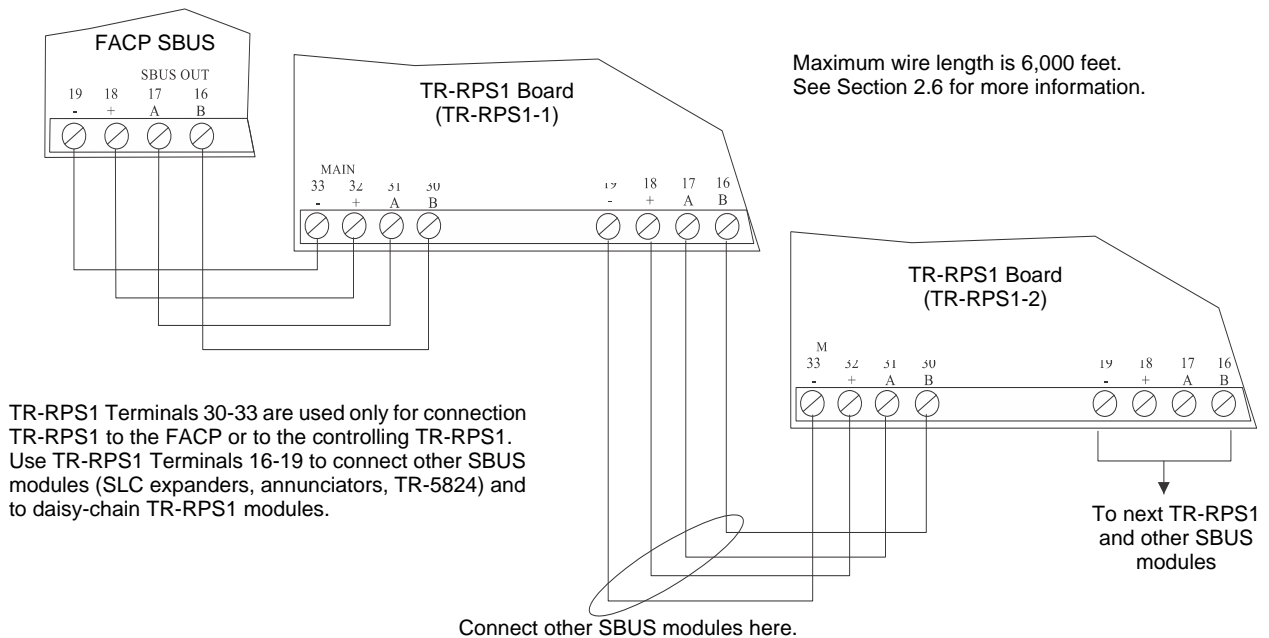

Figure 3.5 Class B TR-RPS1 Connection to FACP

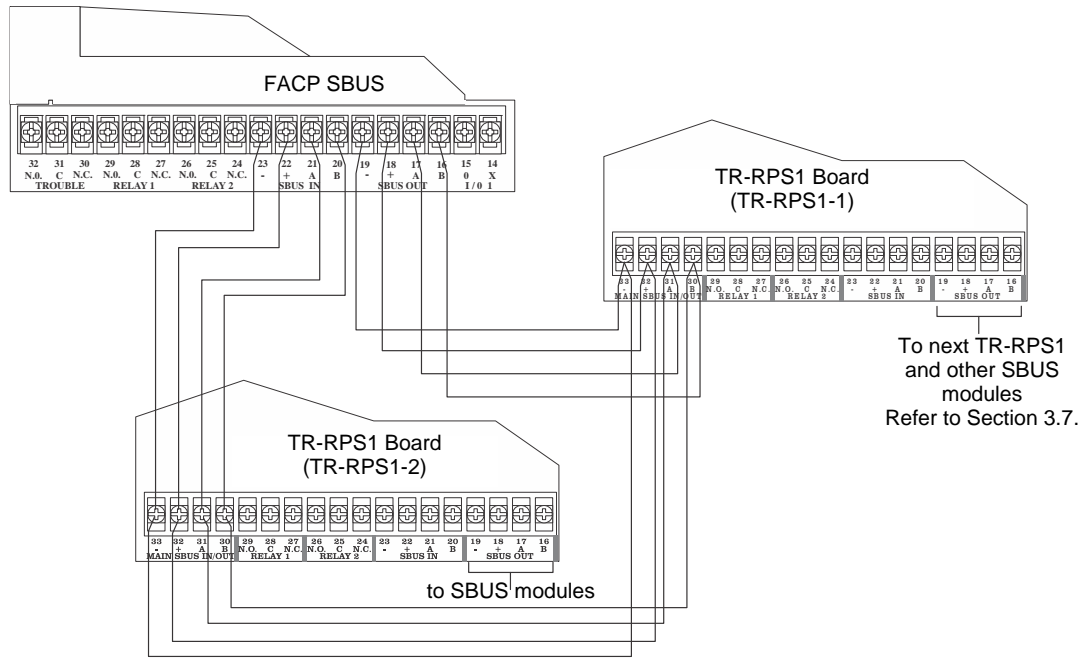
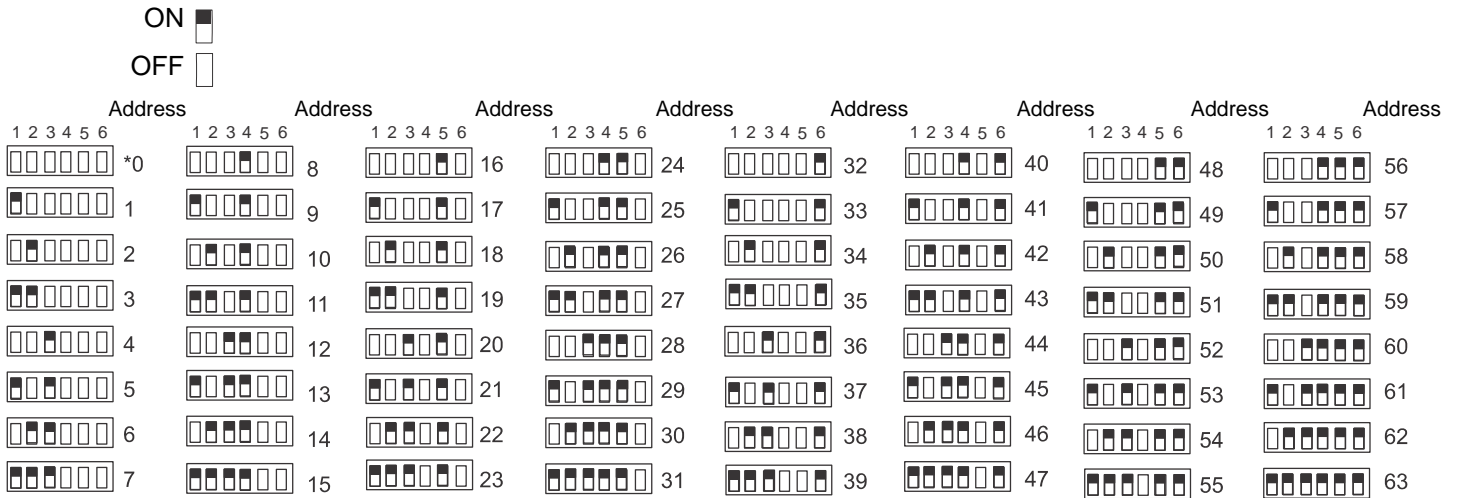

Figure 3.6 Class A TR-RPS1 Connection to FACP

3.6.1 Setting the Device ID

All SBUS modules in the system must have a unique number to identify them to the FACP. The actual number of SBUS devices available is limited by current draw and SBUS bandwidth usage. When installing the TR-RPS1, use the DIP switches on the module to assign an ID# to the module. Address zero is an invalid address and is not allowed. Figure 3.7 shows all possible DIP switch positions and their correlation to the numerical ID.



*Address 0 is invalid and cannot be used.

Figure 3.7 Device ID Addresses

3.7 Connecting SBUS Modules to the TR-RPS1

1. Connect SBUS modules to the TR-RPS1 as shown in Figure 3.8 or Figure 3.9.
2. All SBUS modules must have an ID. Use the DIP switches on the module board to assign an ID number (1-31) to the module. This number identifies the module to the TR-RPS1 and must be unique.
3. Software configuration steps vary for each SBUS module. For more information, refer to the FACP installation manual.

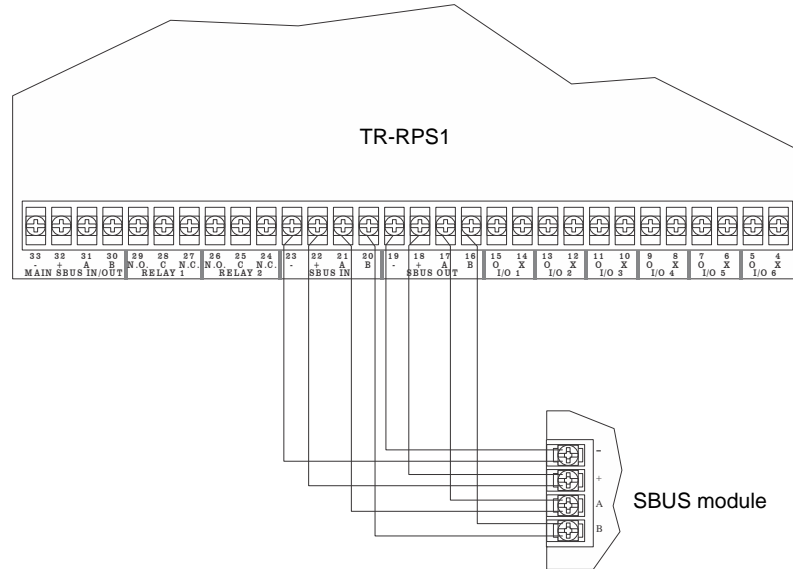

Figure 3.8 SBUS Class A Connection to TR-RPS1

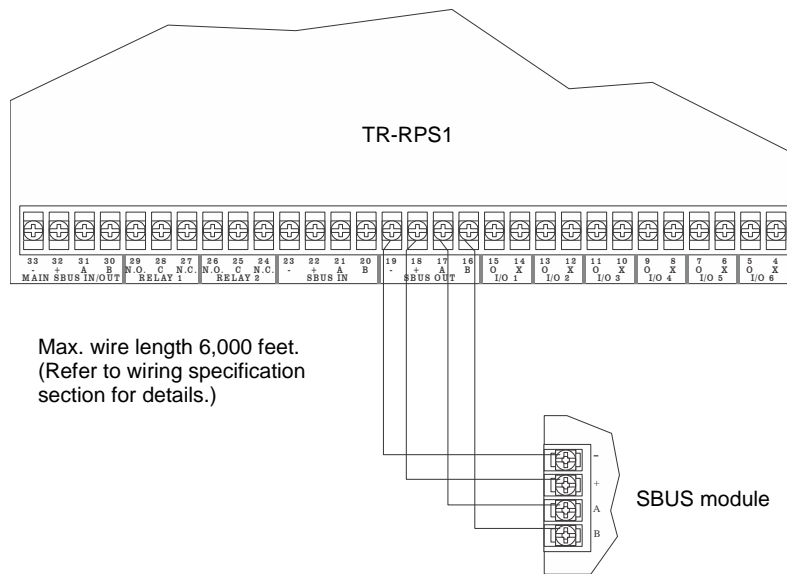

Figure 3.9 SBUS Class B Wiring to TR-RPS1

3.8 Flexput I/O Circuits

The six Flexput circuits are an innovative and versatile feature of the TR-RPS1 panel. They can be used as: Class A or Class B notification circuits, Class A or B initiation circuits (either 2-wire or 4-wire detectors), or as auxiliary power circuits (resettable, continuous, or door holder).

This section of the manual explains how to install the conventional notification appliances and the initiating devices to be used with the TR-RPS1.

3.8.1 Releasing Operations

Approved releasing solenoids are list in the *Device Compatibility Document*. Do not mix cross alarming zones with smoke verification zones. There must be at least two automatic detection devices in each protected space. Spacing must be reduced to 0.7 times the linear spacing in accordance with NFPA 72.

An MRD-1 Manual Release Disconnect Switch can be used to disconnect the releasing circuits for testing and maintenance. Do not rely on disable/enable software settings to lock out releasing devices. Releasing devices must be physically disconnected per UL 864 10th Edition. Refer to the *MRD-1 Installation Document* #LS10231-000GE-E for more information.

3.8.2 Conventional Notification Appliances

This sub-section of the manual explains how to install the conventional notification appliances for Class A and Class B configurations.

Class B Notification Wiring

Use UL listed notification appliances only. Circuits are supervised, power-limited, and regulated. Refer to the *Device Compatibility Document* for a list of compatible notification appliances.

To install a Class B notification appliance circuit, wire notification appliances as shown in Figure 3.10 and configure the circuit in FACP programming.

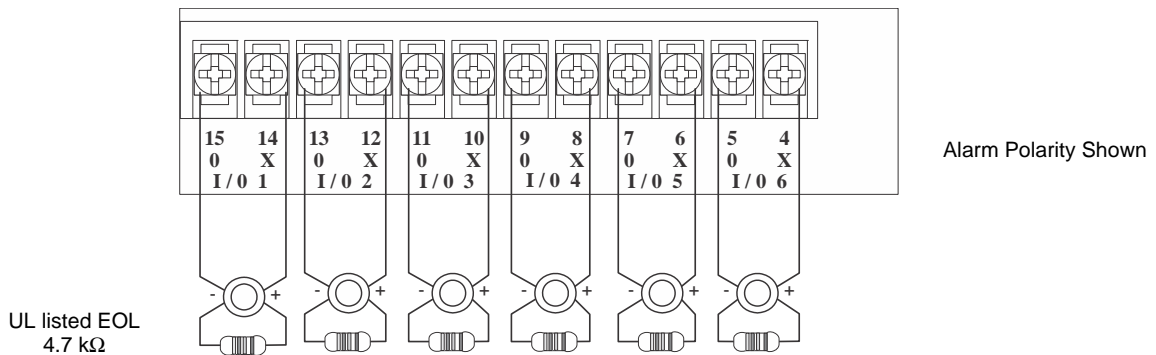

Figure 3.10 Class B Notification Appliance Circuit Wiring

Class A Notification Wiring

Use UL listed notification appliances only. Circuits are supervised, power-limited, and regulated. Refer to the *Device Compatibility Document*, for a list of compatible notification appliances.

To install a Class A notification appliance circuit, wire notification appliances as shown in Figure 3.11 and configure the circuit in FACP programming.

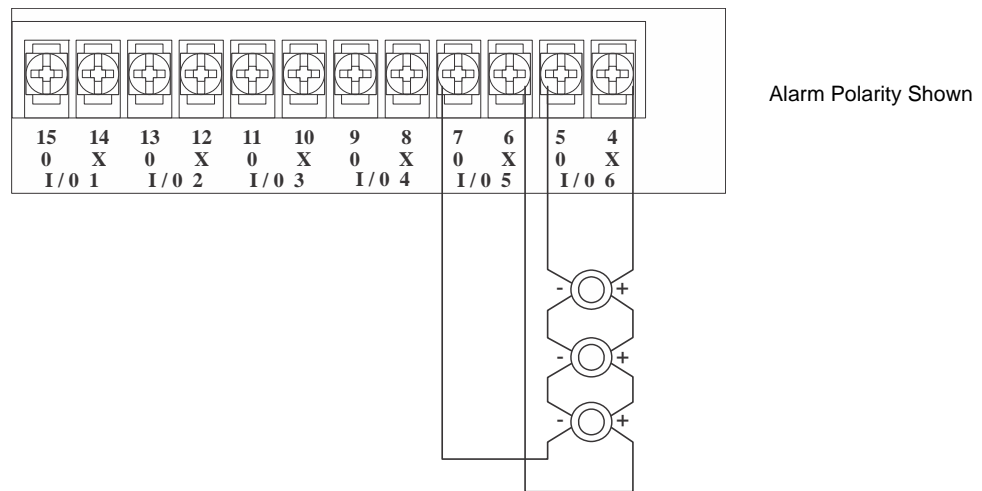

Figure 3.11 Class A Notification Appliance Circuit Configuration



NOTE: In programming, any point that uses multiple I/O circuits are always referred to as the lowest I/O circuit number used. For example, Figure 3.11 uses both I/O circuit 5 and 6, so in programming it would be referred to as point 5.

3.8.3 Conventional Initiation Circuits

This Section of the manual explains how to install the conventional initiating devices for Class A or Class B configurations.

Class B Inputs

Connect conventional Class B switches, such as waterflow switches and pull stations, directly to the I/O circuits of the TR-RPS1 panel. To install a Class B switch, wire the switch as shown in Figure 3.12 and configure the circuit through FACP programming.

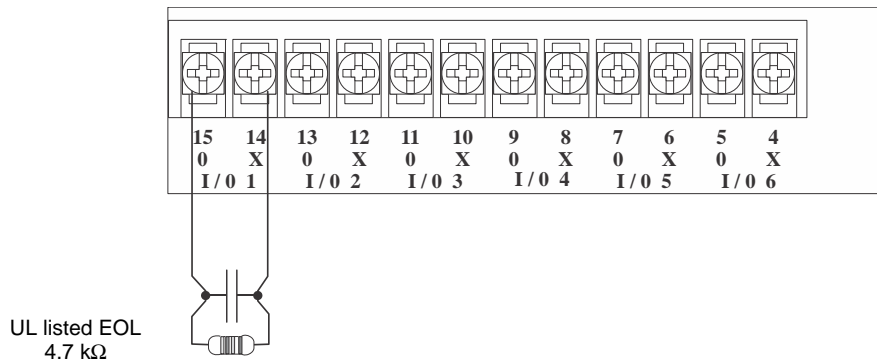

Figure 3.12 Class B Input Switches

Class A Inputs

Connect conventional Class A switches, such as waterflow switches and pull stations, directly to the I/O circuits of the TR-RPS1 panel. To install a Class A switch, wire the switch as shown in Figure 3.13 and configure the circuit through FACP programming.

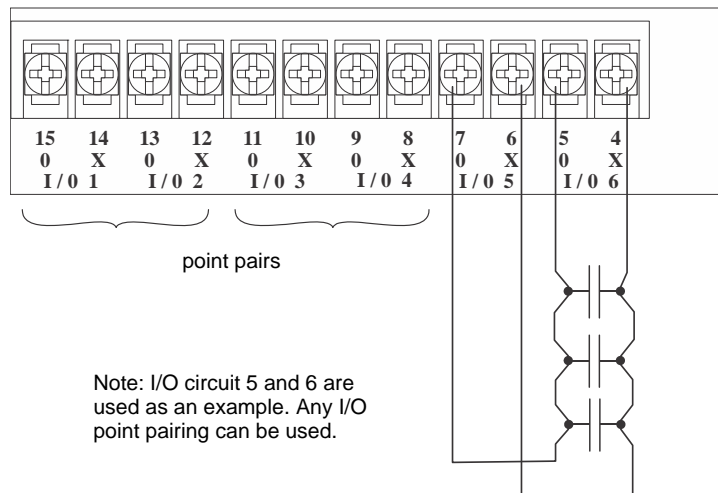

Figure 3.13 Class A Initiating Switches



NOTE: In programming, any point that uses the multiple I/O circuits are always referred to as the lowest I/O circuit number used. For example, since Figure 3.13 uses both I/O circuit 5 and 6, it would be referred to as point 5.

3.8.4 Installing 2-Wire Smoke Detectors

Any compatible UL listed two-wire smoke detector can be used with the TR-RPS1 panel. Refer to the *Device Compatibility Document* for a list of compatible devices. Figure 3.14 and Figure 3.15 illustrate how to connect a UL listed 2-wire detector to the TR-RPS1 panel.

Class B Installation

To install a Class B two-wire smoke detector, wire as shown in Figure 3.14.

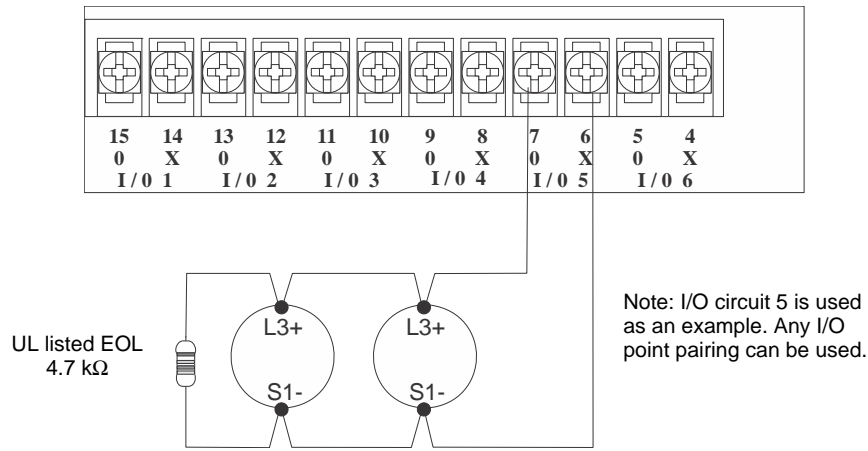

Figure 3.14 Two-Wire Class B Smoke Detector

Class A Smoke Detector Installation

To install a Class A two-wire smoke detector, wire as shown in Figure 3.15.

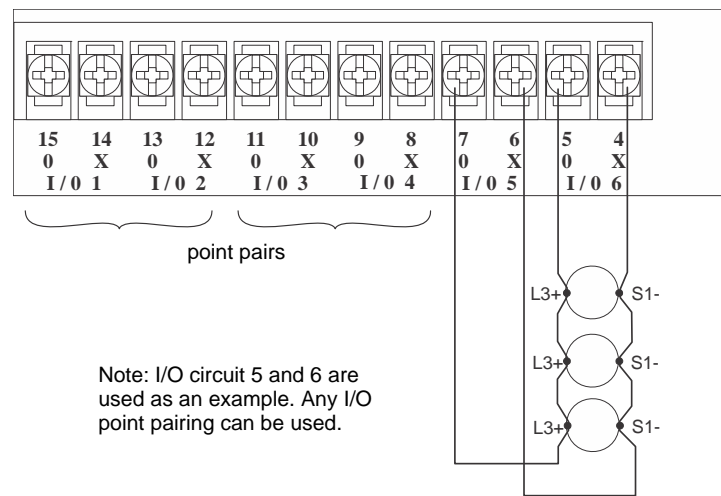

Figure 3.15 Two-Wire Class A Smoke Detector Connections



NOTE: In programming, any point that uses multiple I/O circuits are always referred to as the lowest I/O circuit number used. For example, since Figure 3.15 uses both I/O circuit 5 and 6, it would be referred to as point 5.

3.8.5 Installing 4-Wire Smoke Detectors

Any compatible UL listed two-wire smoke detector can be used with the TR-RPS1 panel. Refer to the *Device Compatibility Document* for a list of compatible devices. Figure 3.16 and Figure 3.17 illustrate how to connect a UL listed four-wire detector to the TR-RPS1 panel.

Installing Class B 4-Wire Smoke Detectors

Figure 3.16 illustrates how to install Class B 4-wire smoke detectors.

1. Up to three Class B 4-wire smoke detector loops can be connected at once to the TR-RPS1 panel.
2. Each Class B loop input is paired with a unique power source as shown in Figure 3.16.
3. Each loop gets smoke power from the even numbered I/O circuit and the contact input is connected to the odd numbered I/O circuit.

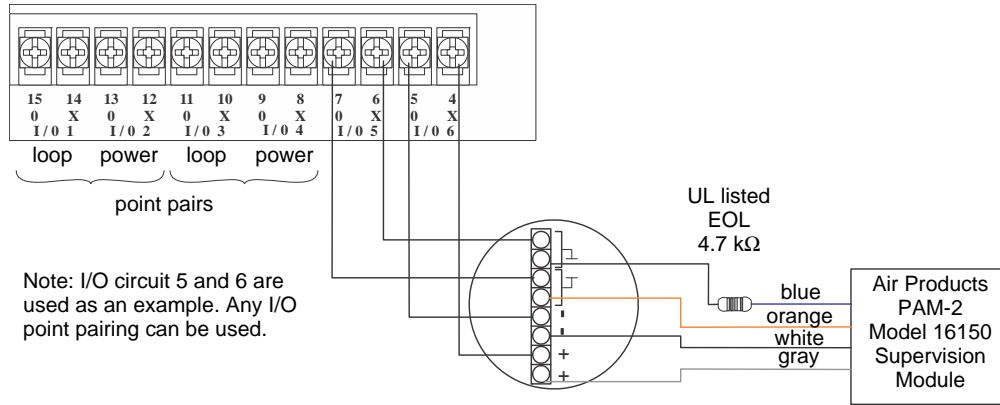

Figure 3.16 Class B 4-Wire Smoke Detector Connections



NOTE: In programming, any point that uses multiple I/O circuits are always referred to as the lowest I/O circuit number used. For example, Figure 3.16 uses both I/O circuit 5 and 6, so in programming it would be referred to as point 5.

Installing Class A 4-Wire Smoke Detectors

Figure 3.17 illustrates how to install Class A 4-wire detectors.

1. Up to two Class A 4-wire loops can be connected to the control panel at once.
2. Smoke power is supplied to each Class A loop as shown in Figure 3.17.

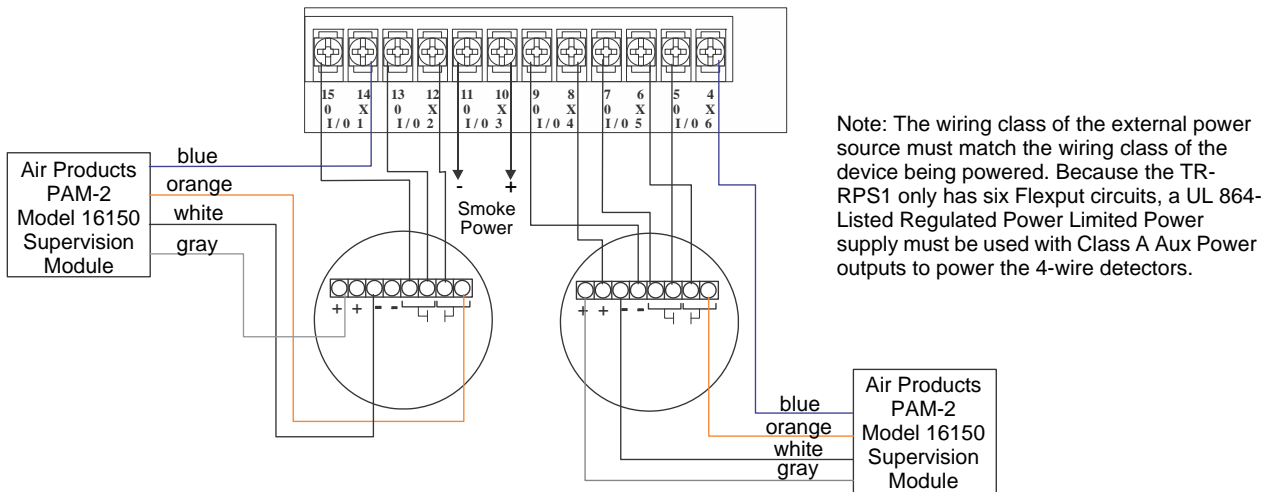

Figure 3.17 Class A 4-Wire Smoke Detector Connections



NOTE: In programming, any point that uses multiple I/O circuits are always referred to as the lowest I/O circuit number used. For example, since Figure 3.17 uses I/O circuits 1, 2, 3 together and 4, 5, 6 together they would be referred to as point 1 and point 4.

3.8.6 Auxiliary Power Configuration

Flexput circuits 1-6 on the control panel can be used as auxiliary power circuits. The four types of auxiliary power available are as follows:

- Door Holder
- Constant
- Resettable
- Sounder Sync Power

Auxiliary power must be wired in Class A configuration per UL864 10th Edition. Auxiliary power circuits are power-limited. Each circuit provides up to 3A (total current for all Flexput circuits must not exceed 5A).

To configure a Flexput circuit as auxiliary power:

1. Wire the Flexput circuit(s) that will be used for auxiliary power. See Figure 2.1 for location of Flexput circuits. When used as auxiliary power, terminals labeled “0” are negative and terminals labeled “X” are positive.
2. Configure the auxiliary power output through programming for Door Holder, Constant or Resettable power.

Door Holder Power

The door holder is intended for fire door applications. When there are no alarms in the system and the panel has AC power, the door holder circuits have 24VDC power present at their terminals. Any alarm will cause power to discontinue. When the system is reset, the power will be reapplied. If the AC power is off for more than 15 seconds, the auxiliary door holder power will be discontinued to conserve the battery backup power. When the AC power is restored, the power is immediately restored to the door holder circuits.

Constant Power

Use the constant power for applications that require a constant auxiliary power source. The power is always present at constant circuits.

Resettable Power

The resettable power is typically used to power the beam detectors, flame detectors, and conventional 4-wire smoke detectors. For circuits selected as Resettable, 24VDC power is always present at the terminals unless a system reset occurs. If a system reset occurs, the power is removed from the terminals for 30 seconds, then the power is reapplied.

Sounder Sync Power

The Sounder Sync Power continuously outputs the System Sensor synchronization pattern and is intended for use with the B200S Series sounder bases.

3.9 Conventional Relay Installation

TR-RPS1 relay circuits are installed in exactly the same way as the FACP main panel relay circuits. For ease of installation, TR-RPS1 output terminals use the same numbering scheme as FACP terminals. For information on installing the conventional relays, refer to the FACP Installation Manuals in Table 1.1.



TRIGA Life Safety Systems, LLC

7600 Olde Eight Rd.

Hudson, OH 44236-1057

Telephone: +1-330-577-5199

www.trigaglobal.com

